

# Radartutorial

## Book 2 „Radar Sets“

### Preamble:

Radar systems come in a variety of sizes and have different performance specifications. Some radar systems are used for air-traffic control at airports and others are used for long-range surveillance and early-warning systems. A radar system is the heart of a missile guidance system. Small portable radar systems that can be maintained and operated by one person are available as well as systems that occupy several large rooms.

### Table of Contents:

<b>Radartutorial</b> .....	<b>1</b>
Preamble: .....	1
Table of Contents: .....	1
Learning Objectives: .....	1
<b>Classification of Radar Systems (1)</b> .....	<b>2</b>
Imaging Radar / Non-Imaging Radar .....	2
Primary Radar .....	2
Pulse Radar .....	2
Pulse Radar using Pulse Compression .....	3
Monostatic / Bistatic Radars .....	3
Secondary Radar .....	3
Principle of operation .....	3
Comparison Primary Radar vs. Secondary Radar .....	4
Continuous Wave Radar .....	4
Block Diagram of an CW-Radar .....	5
Speed gauges .....	5
Frequency Modulated CW radar .....	5
<b>Classification of Radar Sets (2)</b> .....	<b>6</b>
Air-defense Radars .....	6
Examples of Battlefield Radars .....	7
Weapon Control Radar .....	7
Multi Function Radars .....	7
Multi- Target Tracking Radar .....	7
Mortar Locating Radar .....	8
Air Traffic Control (ATC) Radars .....	8
En Route Radars .....	8
Air Surveillance Radar (ASR) .....	8
Precision Approach Radar (PAR) .....	8
Surface Movement Radar (SMR) .....	8
Special Weather Radar Applications .....	8
<b>Radar Frequency Bands</b> .....	<b>9</b>

### Learning Objectives:

This book gives an overview about the wide range of radar systems. The student should know the differences between primary and secondary radars and can explain both the advantages and disadvantages of these two different radar systems.

## Classification of Radar Systems (1)

Depending on the desired information, radar sets must have different qualities and technologies. One reason for these different qualities and techniques radar sets are classified in:

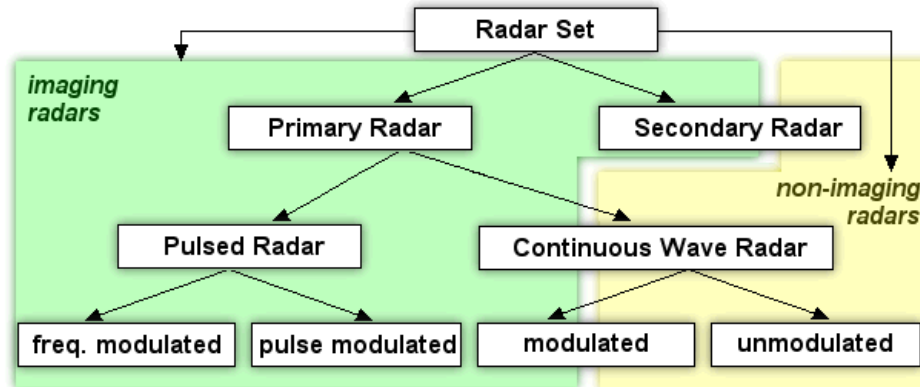

Figure 1: Radar systems classified according to specific function

### Imaging Radar / Non-Imaging Radar

Imaging radar sensors measure two dimensions of co-ordinates at least for a calculating of a map-like picture of the area covered by the radar beam. An imaging radar forms a picture of the observed object or area. Imaging radars have been used to map the Earth, other planets, asteroids, other celestial objects and to categorize targets for military systems.

Non-imaging sensors take measurements in one linear dimension, as opposed to the two dimensional representation of imaging sensors. Typically implementations of a non-imaging radar system are speed gauges and radar altimeters. These are also called scatterometers since they measure the scattering properties of the object or region being observed. Non-imaging secondary radar applications are immobilizer systems in some recent private cars.

### Primary Radar

A Primary Radar transmits high-frequency signals which are reflected at targets. The arisen echoes are received and evaluated. This means, unlike secondary radar sets a primary radar unit receive its own emitted signals as an echo again. Primary radar sets are fitted with an additional interrogator as secondary radar mostly, to combine the advantages of both systems.

### Pulse Radar

Pulse radar sets transmit a high-frequency impulse signal of high power. After this impulse signal, a longer break follows in which the echoes can be received, before a new transmitted signal is sent out. Direction, distance and sometimes if necessary the height or altitude of the target can be determined from the measured antenna position and propagation time of the pulse-signal. These classically radar sets transmit a very short pulse (to get a good range resolution) with an extremely high pulse-power (to get a good maximum range).



Figure 2: A monopulse secondary surveillance radar antenna (looks like a lattice fence) mounted on top of an antenna of a primary radar (parabolic reflector)

## Pulse Radar using Pulse Compression

These radar sets transmit a relatively weak pulse with a longer pulse-width. It modulates the transmitting signal to obtain a distance resolution also within the transmitting pulse with help of the pulse-compression.

## Monostatic / Bistatic Radars

Monostatic radars are deployed in a single site. Transmitter and receiver are collocated and the radar uses the same antenna mostly.

Bistatic radar consists of a separated (by a considerable distance) transmitting and receiving sites.

## Secondary Radar

At secondary radar sets the airplane must have a transponder (**transmitting responder**) on board and this transponder responds to interrogation by transmitting a coded reply signal. This response can contain much more information, than a primary radar unit is able to acquire (E.g. an altitude, an identification code or also any technical problems on board such as a radio contact loss ...).

### Principle of operation

The interrogator on the ground transmits coded pulses with different modes. Every mode represents a different question. For conventional SSR (i.e. not mode-S) the choice of questions is very simple. The controller wants to know the identity of the aircraft („Who are you?“). The Radar gives a 2 dimensional position fix of the aircraft, but air traffic control is very much a 3 dimensional process, so „What height are you?“ completes the positional fix. These different questions determine the MODE of operation. The aircrafts transponder reply with a CODE.

The chosen mode is encoded in the Coder. (By the different modes different questions can be defined to the airplane.) The transmitter modulates these coded impulses with the RF frequency. Because another frequency than on the replay path is used on the interrogation path, an expensive duplexer can be renounced. The antenna is usually mounted on the antenna of the primary radar unit (as shown in Figure 2) and turns synchronously to the deflection on the monitor therefore.

A receiving antenna and a transponder are in the airplane. The receiver amplifies and demodulates the interrogation impulses. The decoder decodes the question according to the desired information and induces the coder to prepare the suitable answer. The coder encodes the answer. The transmitter amplifies the replays impulses and modulates these with the RF reply-frequency.

Again in the interrogator on the ground: The receiver amplifies and demodulates the replay impulses. Jamming or interfering signals are filtered out as well as possible at this.

From the information „Mode“ and „Code“ the decoder decodes the answer. The display of the primary radar represents the additional interrogator information. Perhaps additional numbers must be shown on an extra display.

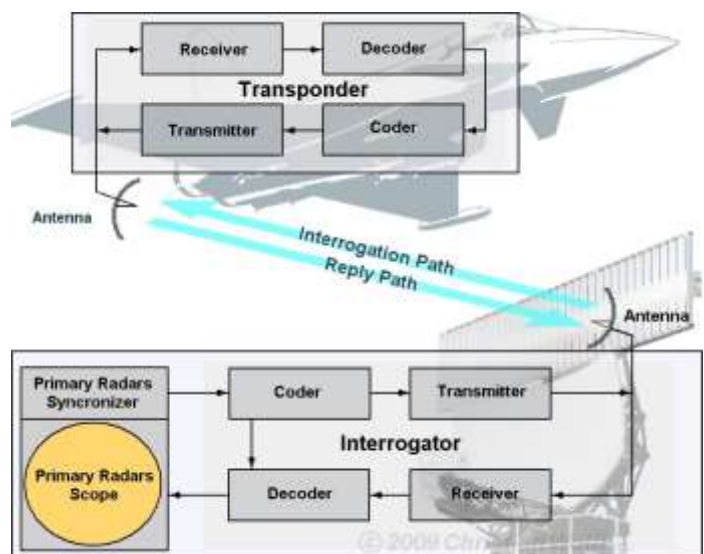

Figure 3: simple block diagram of secondary surveillance radar

## Comparison Primary Radar vs. Secondary Radar

### Primary Surveillance Radar (PSR)

The primary radar unit has a major quality: It works with passive echoes. The transmitted high-frequency impulses are reflected by the target and then received by the same radar unit. Well, direct cause of the reflected echo is the transmitting impulse sent out by the radar unit.

### Secondary Surveillance Radar (SSR)

Secondary radar units work according to another principle: These work with active answer signals. The secondary radar unit transmits and also receives high-frequency impulses, the so called interrogation. This isn't simply reflected, but received by the target by means of a transponder which receives and processes. After this the target answers with another frequency, the response telegram which is produced and transmitted.

Both systems have advantages and disadvantages due to the different principles. If one wins safe information about direction, height and distance of the targets with the primary radar, then the secondary surveillance radar still provides additional information, like signal identification and also the altitude of the targets.

The cooperation of the target (transponder) is necessary to reach a drastic reduction of the transmit power in case of the same maximum range. Because the transmit power influences the radar equation at the primary radar with the two way travel, at the secondary surveillance radar only one way.

$$R \sim \sqrt[4]{P_{PSR}} = \sqrt[2]{P_{SSR}}$$

Eqn. 1: two-way free-space path loss by PSR versus one-way free-space path loss by SSR

A factor > 1000 as a guide value can be assumed. From this a substantially simpler, smaller and cheaper transmitter follows. The receiver can be more insensitive, since the power of the active answers is higher than the power of the passive echoes. This circumstance adversely affects, however, the influence of the side lobes. This must be compensated by using suitable measures of the side lobe suppression.

Since the transmitting frequency and receiving frequency are different, no clutter disturbances arise. No MTI-system therefore is needed to the compensation of ground clutter. On the other hand a frequency change is impossible by jamming. Special disturbances at secondary radar equipment make additional wiring measures necessary.

## Continuous Wave Radar

CW radar sets transmit a high-frequency signal continuously. The echo signal is received and processed permanently too. The transmitted signal of this equipment is constant in amplitude and frequency. This radar is specialized in speed measuring. E.g. these radars are used as speed gauges of the police. One has to resolve two problems with this principle:

- to prevent a direct connection of the transmitted energy into the receiver (feedback connection),
- to assign the received echoes to a time system to be able to do run time measurements.

A direct connection of the transmitted energy into the receiver can be prevented by:

- spatial separation of the transmitting antenna and the receiving antenna, e.g. the aim is illuminated by a strong transmitter and the receiver is located in the missile flying direction towards the aim;
- frequency dependent separation by the Doppler-frequency during the measurement of speeds.

A run time measurement isn't necessary for speed gauges, the actual range of the delinquent car doesn't have a consequence. If you need range information, then the time measurement can be realized by a frequency modulation or phase keying of the transmitted power. A CW-radar transmitting a unmodulated power can measure the speed only by using the Doppler-effect. It cannot measure a range and it cannot differ between two reflecting objects.

## Block Diagram of an CW-Radar

Simple CW Doppler- Radar sets have a design shown in Figure 5.

The generator generates very stable RF-Frequency  $f_s$ . A second generator generates the IF-frequency  $f_{ZF}$ . A mixer stage with a following narrowband filter generates the stable local-oscillator-frequency  $f_s+f_{ZF}$  as sum of the transmitter's frequency and a generated IF-frequency. As a part of the superheterodyne receiver the next mixer stage converts the backscattered RF-signals  $f_s+f_D$  to the IF- frequency. The IF-amplifier makes the receiver very sensitive for the weak echo signals. The output of the last mixer stage is the Doppler-frequency  $f_D$  only. The frequency counter counts the Doppler-frequency and by means of this counted value calculates the speed. In order to obtain a precise result, this calculation procedure must be calibrated in accordance by an exactly specified radiation angle to the carriageway.

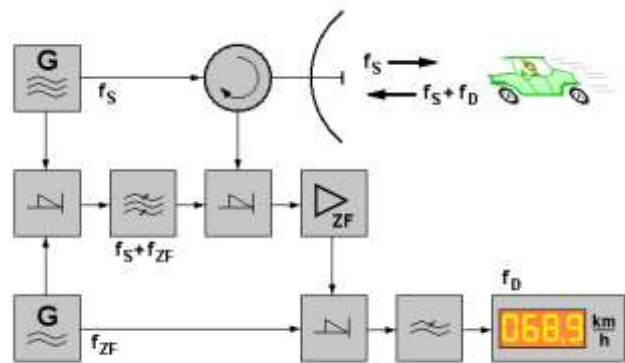

Figure 4: Schematic diagram of a CW Doppler- Radar

## Speed gauges

Speed gauge is a very specialized CW-radar. Transmitting unmodulated power it can measure the speed only by using the Doppler- effect. It cannot measure a range and it cannot differ between two reflecting objects. A run time measurement isn't necessary for speed gauges, the actual range of the delinquent car doesn't have a consequence. If you need range information, then the time measurement can be realized by a frequency modulation or phase keying of the transmitted power.



Figure 5: Speed gauge "Traffipax SpeedoPhot" (ROBOT Visual Systems GmbH)

Since the value of the Doppler- frequency depends on the wavelength, these radar sets use a very high frequency band. Figure 5 shows the speed gauge „Traffipax Speedophot“. This radar operates at frequency of 24.125 gigahertz's.

It can measure the speed of the incoming and the outgoing traffic, from the right or left border of the street. The radar can be mounted in a car or on a tripod. The traffic offence can be circumstantiated by a photo camera with high resolution.

## Frequency Modulated CW radar

CW radars have the disadvantage that they cannot measure distance, because there are no pulses to time. In order to correct for this problem, frequency shifting methods can be used. In the frequency shifting method, a signal that constantly changes in frequency around a fixed reference is used to detect stationary objects. When a reflection is received the frequencies can be examined, and by knowing when in the past that particular frequency was sent out, you can do a range calculation similar to using a pulse. It is generally not easy to make a broadcaster that can send out random frequencies cleanly, so instead these Frequency-Modulated Continuous Wave radars (FMCW), use a smoothly varying „ramp“ of frequencies up and down.

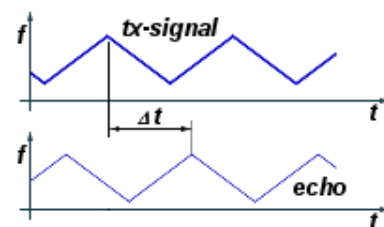

Figure 6: Ranging with a FMCW system

$$R = \frac{c_0 \cdot \Delta t}{2}$$

Where:  $c_0$  = speed of light =  $3 \cdot 10^8$  m/s  
 $\Delta t$  = measured time-difference [s]  
 $R$  = distance altimeter to terrain [m] (2)

This kind of radar is used as “radar altimeter” often. The radar altimeter is used to measure the exact height during the landing procedure of aircraft. Radar altimeters are also a component of terrain avoidance warning systems, telling the pilot that the aircraft is flying too low or that terrain is rising to meet the aircraft.

## Classification of Radar Sets (2)

Radar systems may be divided into types based on the designed use. This section presents the general characteristics of several commonly used radar systems:

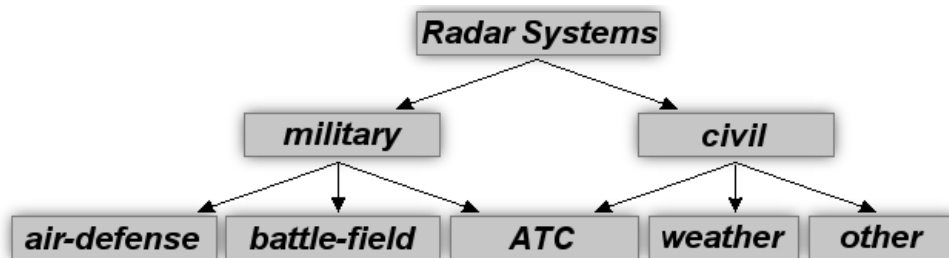

Figure 7: Classification of radar sets according its use

Although any and every radar can be abused as military radar, the necessary distinction as military or civil radar has legal causes often.

## Air-defense Radars

Air-Defense Radars can detect air targets and determine their position, course, and speed in a relatively large area. The maximum range of Air-Defense Radar can exceed 300 miles, and the bearing coverage is a complete 360-degree circle. Air-Defense Radars are usually divided into two categories, based on the amount of position information supplied. Radar sets that provide only range and bearing information are referred to as two-dimensional, or 2D, radars. Radar sets that supply range, bearing, and height are called three-dimensional, or 3D, radars.

Air-Defense Radars are used as early-warning devices because they can detect approaching enemy aircraft or missiles at great distances. In case of an attack, early detection of the enemy is vital for a successful defense against attack. Antiaircraft defenses in the form of anti-aircraft artillery (abbreviated to „AAA“), missiles, or fighter planes must be brought to a high degree of readiness in time to repel an attack. Range and bearing information, provided by Air-Defense Radars, used to initially position a fire-control tracking radar on a target.

Another function of the Air-Defense Radar is guiding combat air patrol (CAP) aircraft to a position suitable to intercept an enemy aircraft. In the case of aircraft control, the guidance information is obtained by the radar operator and passed to the aircraft by either voice radio or a computer link to the aircraft.

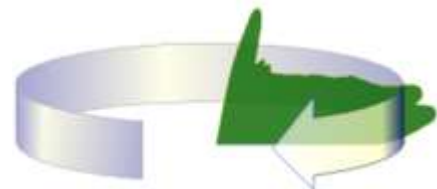

Figure 8: Diagram of a typical 2D-Radar, the rotating cosecant squared antenna pattern

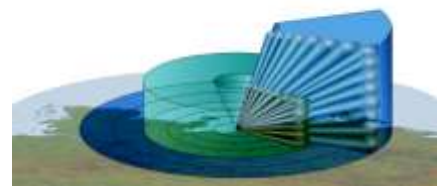

Figure 9: Diagram of a typical 3D-Radar, a mix of vertical electronic beam steering and mechanical horizontal movement of a pencil-beam

Major Air-Defense Radar Applications are:

- Long-range early warning (including airborne early warning, AEW)
- Ballistic missile warning and acquisition
- Height-finding
- Ground-controlled interception (GCI)

## Examples of Battlefield Radars

### Weapon Control Radar

Radar that provides continuously position data on a single target is called tracking radar. Most tracking radar systems used by the military are also fire-control radar; the two names are often used interchangeably.

Typical fire-control radar characteristics include a very high pulse repetition frequency (PRF), a very narrow pulse width, and a very narrow beam width. These characteristics, while providing extreme accuracy, limit the range and make initial target detection difficult.

Fire-control radar must be directed to the general location of the desired target because of the narrow-beam pattern. This is called the designation phase of equipment operation. Once in the general vicinity of the target, the radar system switches to the acquisition phase of operation. During acquisition, the radar system searches a small volume of space in a prearranged pattern until the target is located. Once the target is located, the radar system enters the track phase of operation. Using one of several possible scanning techniques, the radar system automatically follows all target motions. The radar system is said to be locked on to the target during the track phase. The three sequential phases of operation are often referred to as modes and are common to the target-processing sequence of most fire-control radars.

### Multi Function Radars

Active array Multi-Function Radars (MFRs) enable modern weapon systems to cope with saturation attacks of very small radar cross-section missiles in a concentrated jamming environment. Such MFRs have to provide a large number of fire-control channels, simultaneous tracking of both hostile and defending missiles and mid-course guidance commands.

The active phased-array antenna comprises flat sensor panels consisting of arrays of GaAs modules transmitting variable pulse patterns and building up a detailed picture of the surveillance area. A typical fixed array configuration system could consist of about 2,000 elements per panel, with four fixed panels. Each array panel can cover 90° in both elevation and azimuth to provide complete hemispherical coverage.

### Multi- Target Tracking Radar

Operational functions of a Multi- Target Tracking Radar (MTTR) include:

- long-range search;
- search information with high data rate for low-flying aircraft;
- search information with high resolution of close in air targets;
- automatic position and height information;
- simultaneous tracking of a lot of aircraft targets;
- target designation facilities for other systems.



Figure 10: Antenna of a mobile 3D-Air-Defense Radar,



Figure 11: Helicopter and Aircraft Radio Detection (HARD) in the German Engagement Control-Search- and Acquisition system

### Mortar Locating Radar

A Mortar Locating Radar provides quick identification to pinpoint enemy mortar positions in map co-ordinates, enabling artillery units to launch counter attacks. The system electronically, scans the horizon over a given sector several times a second, intercepting and automatically tracking hostile projectiles, then computing back along the trajectory to the origin. The co-ordinates and altitude of the weapon are then presented to the operator.

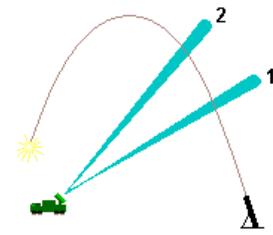

Figure 12: Principle of mortar locating radar

### Air Traffic Control (ATC) Radars

The following Air Traffic Control (ATC) surveillance, approach and landing radars are commonly used in Air Traffic Management (ATM):

- en-route radar systems,
- Air Surveillance Radar (ASR) systems,
- Precision Approach Radar (PAR) systems,
- surface movement radars, and
- special weather radars.



Figure 13: SRE-M7, a typically en-route radar

### En Route Radars

En-route radar systems operate in L-Band usually. These radar sets initially detect and determine the position, course, and speed of air targets in a relatively large area up to 250 nautical miles (NM).

### Air Surveillance Radar (ASR)

Airport Surveillance Radar (ASR) is approach control radar used to detect and display an aircraft's position in the terminal area. These radar sets operate usually in E-Band, and are capable of reliably detecting and tracking aircraft at altitudes below 25,000 feet (7,620 meters) and within 40 to 60 nautical miles (75 to 110 km) of their airport.



Figure 14: ASR-12, a typically Air Surveillance Radar

### Precision Approach Radar (PAR)

The ground-controlled approach is a control mode in which an aircraft is able to land in bad weather. The pilot is guided by ground control using precision approach radar. The guidance information is obtained by the radar operator and passed to the aircraft by either voice radio or a computer link to the aircraft.



Figure 15: PAR 80

### Surface Movement Radar (SMR)

The Surface Movement Radar (SMR) scans the airport surface to locate the positions of aircraft and ground vehicles and displays them for air traffic controllers in bad weather. Surface movement radars operate in J- to X-band and uses an extremely short pulse-width to provide an acceptable range-resolution. SMR are part of the Airport Surface Detection Equipment (ASDE).



Figure 16: SMR Scancer 2001

### Special Weather-Radar Applications

Weather radar is very important for the air traffic management. There are weather-radars specially designed for the air traffic safety.



## Radar Frequency Bands

The spectrum of the electric magnetic waves shows frequencies up to  $10^{24}$  Hz. This very large complete range is subdivided because of different physical qualities in different subranges.

The division of the frequencies to the different ranges was competed on criteria formerly, which arose historically and a new division of the wavebands which is used internationally is out-dated and arose so in the meantime. The traditional waveband name is partly still used in the literature, however. An overview shows the following figure:

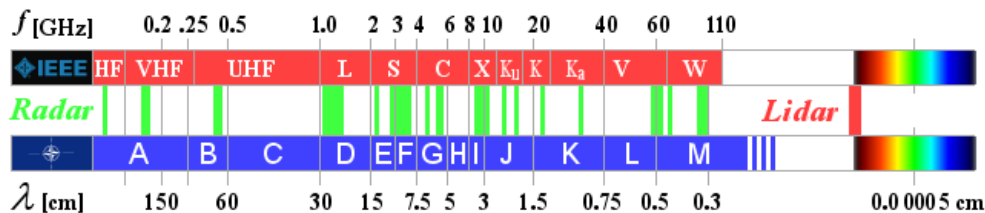

Figure 17: Waves and frequency ranges used by radar.

There are two different significant radar frequency letter-band nomenclatures in use. One system uses a more historically originated system of letters and is defined even as an IEEE-Standard. These letter designations were originally selected to describe the secret radar bands used in World War II. Military Radar-applications in NATO uses another nomenclature with easier abecedarian letters. This system allows an easy extension with higher frequencies and is originally devised for conducting electronic support measures, countermeasures and electronic warfare, and (at least military) radars are an important part of it. The boundaries of the frequency bands are distributed nearly logarithmical.

Since without that the correct frequency is known, a transformation isn't always possible into the newer wavebands with NATO-nomenclature. Often in the manufacturers documents are published the traditional wavebands. The different designations for Radar-Frequency Bands are very confusing. This is no problem for a radar engineer or technician. They can handle with these different bands, frequencies and wave lengths. The problem is now to assert, that a frequency generator for I and J-Band serves the X- and Ku-Band Radars and the D-Band Jammer interferes an L-Band Radar.

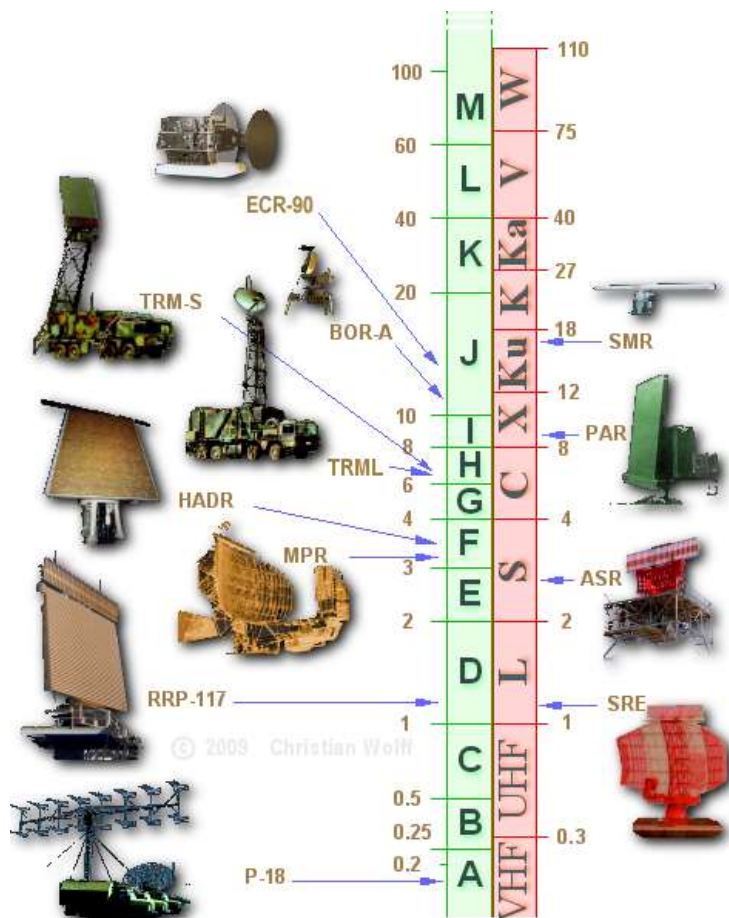

Figure 18: Some radars and its frequency band

Radar systems work in a wide band of transmitted frequencies. The higher the frequency of a radar system, the more it is affected by weather conditions such as rain or clouds. But the higher the transmitted frequency, the better is the accuracy of the radar system.

#### **A- and B- Band (HF- und VHF- Radar)**

These radar bands below 300 MHz have a long historical tradition because these frequencies represented the frontier of radio technology at the time during the World War II. Today these frequencies are used for early warning radars and so called Over The Horizon (OTH) Radars. Using these lower frequencies it is easier to obtain high-power transmitters. The attenuation of the electro-magnetic waves is lower than using higher frequencies. On the other hand the accuracy is limited, because a lower frequency requires antennas with very large physical size which determines angle accuracy and angle resolution. These frequency-bands are used by other communications and broadcasting services too, therefore the bandwidth of the radar is limited (at the expense of accuracy and resolution again). These Frequency bands are currently experiencing a comeback, while the actually used Stealth technologies don't have the desired effect at extremely low frequencies.

#### **C- Band (UHF- Radar)**

There are some specialized Radar sets developed for this frequency band (300 to 1 GHz). It is a good frequency for the operation of radars for the detection and tracking of satellites and ballistic missiles over a long range. These radars operate for early warning and target acquisition like the surveillance radar for the Medium Extended Air Defense System (MEADS). Some weather radar-applications e.g. wind profilers work with these frequencies because the electromagnetic waves are very low affected by clouds and rain.

The new technology of Ultrawideband (UWB) Radars uses all frequencies from A- to C-Band. UWB- radars transmit very low pulses in all frequencies simultaneously. They are used for technical material examination and as Ground Penetrating Radar (GPR) for archaeological explorations.

#### **D- Band (L-Band Radar)**

This frequency band (1 to 2 GHz) is preferred for the operation of long-range air-surveillance radars out to 250 NM ( $\approx 400$  km). They transmit pulses with high power, broad bandwidth and an intrapulse modulation often. Due to the curvature of the earth the achievable maximum range is limited for targets flying with low altitude. These objects disappear very fast behind the horizon.

In Air Traffic Management (ATM) long-range surveillance radars like the Air Route Surveillance Radar (ARSR) works in this frequency band. Coupled with a Monopulse Secondary Surveillance Radar (MSSR) they use a relatively large, but slower rotating antenna. The designator L-Band is good as mnemonic rhyme as large antenna or long range.

#### **E/F-Band (S-Band Radar)**

The atmospheric attenuation is higher than in D-Band. Radar sets need a considerably higher transmitting power than in lower frequency ranges to achieve a good maximum range. As example given the Medium Power Radar (MPR) with a pulse power of up to 20 MW. In this frequency range the influence of weather conditions is higher than in D-band. Therefore a couple of weather radars work in E/F-Band, but more in subtropic and tropic climatic conditions, because here the radar can see beyond a severe storm.

Special Airport Surveillance Radars (ASR) are used at airports to detect and display the position of aircraft in the terminal area with a medium range up to 50...60 NM ( $\approx 100$  km). An ASR detects aircraft position and weather conditions in the vicinity of civilian and military airfields. The designator S-Band (contrary to L-Band) is good as mnemonic rhyme as smaller antenna or shorter range.

#### **G- Band (C-Band Radar)**

In G- Band there are many mobile military battlefield surveillance, missile-control and ground surveillance radar sets with short or medium range. The size of the antennas provides an

excellent accuracy and resolution, but the relatively small-sized antennas don't bother a fast relocation. The influence of bad weather conditions is very high. Therefore air-surveillance radars use an antenna feed with circular polarization often. This frequency band is predetermined for most types of weather radar used to locate precipitation in temperate zone like Europe.

### **I/J- Band (X- and Ku- Band Radars)**

In this frequency-band (8 und 12 GHz) the relationship between used wave length and size of the antenna is considerably better than in lower frequency-bands. The I/J- Band is a relatively popular radar band for military applications like airborne radars for performing the roles of interceptor, fighter, and attack of enemy fighters and of ground targets. A very small antenna size provides a good performance. Missile guidance systems at I/J- band are of a convenient size and are, therefore, of interest for applications where mobility and light weight are important and very long range is not a major requirement.

This frequency band is wide used for maritime civil and military navigation radars. Very small and cheap antennas with a high rotation speed are adequate for a fair maximum range and a good accuracy. Slotted waveguide and small patch antennas are used as radar antenna, under a protective radome mostly.

This frequency band is also popular for space borne or airborne imaging radars based on Synthetic Aperture Radar (SAR) both for military electronic intelligence and civil geographic mapping. A special Inverse Synthetic Aperture Radar (ISAR) is in use as a maritime airborne instrument of pollution control.

### **K- Band (K- and Ka- Band Radars)**

The higher the frequency, the higher is the atmospheric attenuation. Otherwise the achievable accuracy and the range resolution rise too. Radar applications in this frequency band provide short range, very high resolution and high data renewing rate. In ATM these radar sets are called Surface Movement Radar (SMR) or Airport Surface Detection Equipment (ASDE). Using of very short transmitting pulses of a few nanoseconds affords a range resolution, that outline of the aircraft can be seen on the radars display.

### **V-Band**

By the molecular dispersion (here this is the influence of the air humidity), this frequency band stay for a high attenuation. Radar applications are limited for a short range of a couple of meters here.

### **W-Band**

Here are two phenomena visible: a maximum of attenuation at about 75 GHz and a relative minimum at about 96 GHz. Both frequency ranges are in use practically. In automotive engineering small built in radar sets operate at 75...76 GHz for parking assistants, blind spot and brake assists. The high attenuation (here the influence of the oxygen molecules O<sub>2</sub>) enhances the immunity to interference of these radar sets.

There are radar sets operating at 96 to 98 GHz as laboratory equipment yet. These applications give a preview for a use of radar in extremely higher frequencies as 100 GHz.