

## Nanoelectronics: Current Generation, New Formulation of Ohm's Law and Conduction Modes by "Bottom-Up" Approach

Yu.A. Kruglyak<sup>1</sup>, P.A. Kondratenko<sup>2</sup>, Yu.M. Lopatkin<sup>3</sup>

<sup>1</sup> *Odessa State Environmental University, 15, Lvivska str., 65016 Odessa, Ukraine*

<sup>2</sup> *National Aviation University, 1, Komarov ave., 03058 Kyiv, Ukraine*

<sup>3</sup> *Sumy State University, 2, Rymsky-Korsakov str., 40007 Sumy, Ukraine*

(Received 18 January 2013; revised manuscript received 13 February 2013; published online 28 March 2013)

General questions of electronic conductivity, current generation with the use of electrochemical potentials and Fermi functions, elastic resistor model, ballistic and diffusion transport, conductivity modes, n- and p-conductors and graphene, new formulation of the Ohm's law are discussed in the frame of the «bottom-up» approach of modern nanoelectronics.

**Keywords:** Nanoelectronics, Moletronics, Bottom-Up, Ohm's law.

PACS numbers: 71.15.Mb, 71.20. - b, 73.22.Pr, 73.23.Ad, 84.32.Ff, 85.35. - p

### 1. INTRODUCTION

The rapid development of nanoelectronics in the last 10-15 years has led not only to the creation and wide use of nanotransistors and a variety of nanoscale electronic devices, but also to the deeper understanding of the causes of current, exchange and energy dissipation, and the operation principles of nanoscale devices as well as conventional electronic devices [1-4]. Nowadays, the revolutionary changes in electronics require reviewing the content of physics studies at the university. A similar revolutionary situation was 50 years ago after the discovery of the transistor, which led not only to the widespread use of microelectronic devices, but also to a radical revision of the university and engineering courses of General Physics, not to mention the special courses in electronics and related disciplines. The materials and substances used in electronics are characterized by such integral properties as carrier mobility and optical absorption coefficient, with further use to explain the observed physical phenomena and modeling of various electronic devices from the time of formation physics of solid state. Now with the shift to meso- and nanoscopic the nano- and molecular transistors require using of laws of quantum mechanics and non-equilibrium statistical thermodynamics for its description and simulation from the very outset, which inevitably leads to a revision of university physics courses at the beginning.

According to Ohm's law, the resistance  $R$  and conductance  $G$  of the conductor with length  $L$  and cross-sectional area  $A$  are given by expressions:

$$R \equiv V/I = \rho L/A \quad \text{and} \quad 1/R \equiv G = \sigma A/L, \quad (1)$$

where the resistivity  $\rho$  and its inverse conductivity  $\sigma$  does not depend on the geometry of the conductor and the properties of the material from which the conductor is made. Ohm's law says that length reduction of the conductor several times reduces the resistance in the same number of times. And if we reduce the length of the conduction channel to a very small size, does it mean that the resistance will be almost "neutral earthing"?

With usual "diffusive" motion of electrons through a conductor the mean free path in conductor is less than 1 micron and varies widely, depending on the temperature and the nature of the conductor material. The length of the conduction channel in the current FET is  $\sim 40$  nm, which are few hundred atoms. It is appropriate to ask the question: if the length of the conductor is less than the diffusion length of the mean free path, does the electron motion become ballistic? Will resistance obey Ohm's law in the usual record? And what if one reduces the length of the conduction channel to a few atoms? Does it make sense to speak of the resistance in itself? All these questions were the hot discussion topic 15-20 years ago. Nowadays the answers to these questions are given and reliably supported by numerous experimental data. And even the resistance of the hydrogen molecule was measured. [5]

Attention is drawn to the fact that the impressive success of the experimental nano-electronics didn't have any effect on the way we think, learn, and explain the concept of resistance, conductivity and operation of electronic devices in general. And until now, apparently, for historical reasons the familiar concept of "top-down" from the massive conductors to molecules dominates. This approach was acceptable as long as there was not enough experimental data on the measurement of conductivity of nanoscale conductors. In the last decade, the situation has changed. Vast experimental data are accumulated for large and maximum small conductors. The development of the concept of "bottom-up" conductivity, which was not only found to be complementary to concept of "top-down" but also led to a rethinking of the operation principles of conventional electronic devices, has begun [6-8]. Recall that the concept of "bottom-up" from the hydrogen atom in the direction of the solid dominates in quantum mechanics from the start.

There is another range of problems in nanoelectronics, for which the concept of "bottom-up" is very interesting. This is the transport problem. In conventional electronics transport of particles is described by the laws of mechanics-classical or quantum. Transport in bulk conductors is accompanied by heat, which is de-

scribed by the laws of thermodynamics-conventional or statistical. Processes are reversible in mechanics, and irreversible in thermodynamics. Strictly speaking, it is impossible to separate these two processes – the movement and heat. There is quite different situation in nanoelectronics. Here the process of electron motion and heat are spatially separated: the electrons move elastically, ballistic ("elastic resistance"), and heat generation occurs only at the interface of the conductor and the electrodes. The concept of "elastic resistor" was proposed by Landauer in 1957 [9-11] long before its experimental confirmation in nanotransistors. The concept of "elastic resistor", properly speaking, is an idealization, but it is reliably confirmed by numerous experimental data for the ultra-small nanotransistors. The development of the concept of "bottom-up" [12] has led to the creation of the unified picture of transport phenomena in nanoscale electronic devices as well as in macrodimension ones.

The paper presents the causes of the origin of current and the role of electro-chemical potentials under the concept of "bottom-up" and the Fermi functions in this process. Furthermore, the model of «elastic resistor» is considered and a new formulation of Ohm's law is given. Within the framework of conception "below-up" the general questions of electronic conductivity will also be considered, including the example of graphene.

## 2. THE CAUSE OF THE CURRENT

When asked about the cause of current by applying the potential difference at the ends of the conductor usually refer to the relationship of the current density  $j$  and the external applied electric field  $E$

$$j = \sigma E, \quad (2)$$

in other words, electric field is usually considered the cause of current. The answer is, at the best case, incomplete. Before connecting conductor to the cleats of the voltage source the strong electric fields created by nuclei affects electrons of the conductor and current is still not arise. Why do the strong internal electric fields not cause the movement of electrons, but much weaker external electric field of battery causes movement of electrons? It is usually said that the internal microscopic fields can't cause movement of the electrons, it is necessary to attach an external macroscopic field. This explanation can not be satisfactory. It is impossible definitively separate the internal and external electric fields in present-day experiments of measuring the individual molecules conductivity. We have to take this lesson learned us by present experimental nanoelectronics, and re-ask the question why the electrons move when the battery is connected to the ends of the conductor.

To answer the question about the cause of current from the start we need two concepts – the density of free states, those occupied by electrons per unit energy  $D(E)$  and electrochemical potential  $\mu_0$  (Fig. 1). For simplicity's sake, that will not affect the final conclusions, we will use the point model of conductor (the channel of electron transfer), which assumes the immutability of the density of states  $D(E)$  as they move

along a conductor. If the system comprising the source electrode ( $S$  / Source), conductor  $M$  and stock electrode ( $D$  / Drain) are in equilibrium (shorted), the electrochemical potential  $\mu_0$  is the same everywhere, and all states with  $E < \mu_0$  filled with electrons, and the states with  $E > \mu_0$  are empty (Fig. 1).

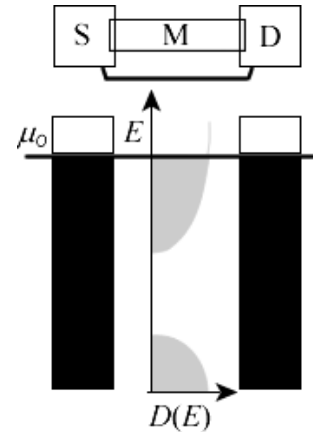

**Fig. 1** – The first step in explaining the operation of any electronic device should be setting the density of states  $D(E)$  as the function of the energy  $E$  in the conductor  $M$  and determination of the equilibrium value of the electrochemical potential  $\mu_0$ , separating the occupied electron states from empty states

When the voltage source in the circuit (Fig. 2) the potential difference  $V$  reduces all energies on the positive electrode  $D$  on the value of  $qV$ , where  $q$  – charge of electron, resulting in the electrodes the electrochemical potential difference is created

$$\mu_1 - \mu_2 = qV. \quad (3)$$

Just as the temperature difference causes heat flow, and the difference in the levels of fluid leads to its flows, and electrochemical potential difference is the cause of the current. Only the state of the conductor in the interval  $\mu_1 - \mu_2$  and located enough close to the values of  $\mu_1$  and  $\mu_2$  contribute to the electron flow, while all the state that are much higher  $\mu_1$  and lower  $\mu_2$  do not play any role. The reason is as follows.

Each contact seeks to lead the current channel to the equilibrium with itself by filling all the states of the channel with electrons with energy less than the electrochemical potential  $\mu_1$ , and emptying of states of channel with energy greater than the potential  $\mu_2$ . Consider the current channel with the states with energy less than  $\mu_1$ , but more  $\mu_2$ . Contact 1 is seeking to fill these states, because their energy is lower than  $\mu_1$ , and contact 2 tends to empty these states because their energy is greater than  $\mu_2$ , which leads to the continuous movement of electrons from contact 1 to contact 2. Now consider the state of the channel with energy greater than  $\mu_1$  and  $\mu_2$ . Both contacts tend to empty these states, but they are empty and do not make their contribution to the electrical current. The situation is similar to the states when energy is less at the same time than both potentials  $\mu_1$  and  $\mu_2$ . Each contact is seeking to fill them with electrons, but they are already filled, and can't make the contribution to the current,

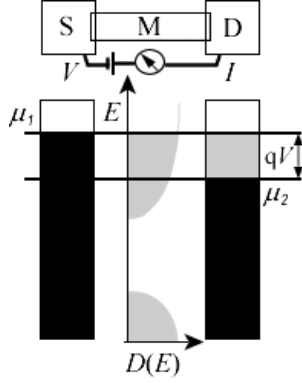

**Fig. 2** – When the voltage  $V$  is applied at the terminals of the conductor the anode potential  $D$  is reduced by the value of  $qV$ , creating the electrochemical potential difference  $\mu_1 - \mu_2 = qV$  at the ends of the conductor

or rather can't make one within a few  $kT$  of the window width of the conduction, that we will see later.

A similar picture is almost self-evident, if not for the usual claim that the electrons move in the electric field inside the conductor. If this was the case, all the electrons, not just those ones, whose state energy lies within the potential difference on the ends of the conductor, would have to make the contribution to the current.

### 3. THE ROLE OF THE FERMI FUNCTIONS

Thus, it was argued that in equilibrium all states with energy  $E < \mu_0$  are filled with electrons and the states with energy  $E > \mu_0$  are empty. This is true only to near of absolute zero. More precisely, the transition from the fully filled states to empty ones occurs in the gap  $\sim \pm 2 kT$ , covering the value  $E = \mu_0$ , where  $k$  – Boltzmann constant,  $T$  – absolute temperature. Mathematically, this transition is described by the Fermi function

$$f(E) = \frac{1}{\exp\left(\frac{E - \mu_0}{kT}\right) + 1} \quad (4)$$

Graph of the Fermi function is shown in Fig. 3 on the left, perhaps in a slightly unusual form of energy in dimensionless units on the vertical axis, which will later allow us to combine Fermi function with graph of the density of states  $D(E)$  in order to explain the reasons for current generation.

Fermi function plays the key role in statistical mechanics, but also for our purposes enough to understand that the state with the low energy are always occupied ( $f = 1$ ), while the states with high energy are always empty ( $f = 0$ ), and the transition from  $f = 1$  to  $f = 0$  occurs in the narrow energy range  $\sim \pm 2 kT$ , covering the value  $E = \mu_0$ .

Indeed, in Fig. 3 it is shown the derivative of the Fermi function, multiplied by  $kT$  in order to make it dimensionless

$$F_T(E, \mu) = kT \left( -\frac{\partial f}{\partial E} \right) \quad (5)$$

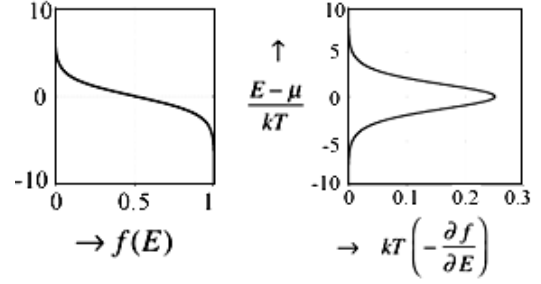

**Fig. 3** – Graphs of the Fermi function and the normalized function of thermal broadening

Substituting the expression for (4), we see that

$$F_T(E, \mu) = \frac{e^x}{(e^x + 1)^2}, \quad (6)$$

where  $x \equiv (E - \mu) / kT$ . From (6) we see immediately that

$$F_T(E, \mu) = F_T(E - \mu) = F_T(\mu - E) \quad (7)$$

and from equations (6) and (4) it follows that

$$F_T = f(1 - f). \quad (8)$$

Integrating of the function (8) in the entire range of energy gives the area equal  $kT$

$$\int_{-\infty}^{+\infty} dE F_T(E, \mu) = kT \int_{-\infty}^{+\infty} dE \left( -\frac{\partial f}{\partial E} \right) = kT [-f]_{-\infty}^{+\infty} = kT(1 - 0) = kT \quad (9)$$

So that the function  $F_T$  can roughly be thought of as a rectangular “impulse”, centered about the meaning of  $E = \mu_0$  with height equal to  $1/4$  and width about  $4 kT$ .

### 4. OUT OF BALANCE

When the system (Fig. 1) is in equilibrium, the electrons are distributed according to the available states according to the Fermi function. There are no simple rules for calculation of the electron distribution function when out of balance. It all depends on the specific task to be solved by the methods of nonequilibrium statistical mechanics.

In this special case of out of equilibrium (Fig. 2) you can be safely argued that both contacts  $S$  and  $D$  are so large compared to the electron-transfer channel that they can't get out of equilibrium. Each contact locally is in equilibrium with its own electrochemical potential, producing two Fermi function (Fig. 4)

$$f_1(E) = \frac{1}{\exp\left(\frac{E - \mu_1}{kT}\right) + 1} \quad (10)$$

and

$$f_2(E) = \frac{1}{\exp\left(\frac{E - \mu_2}{kT}\right) + 1} \quad (11)$$

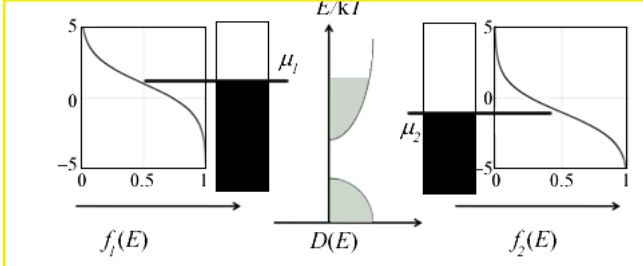

**Fig. 4** – When they get out of balance the electrons in the contacts take available to them the states in accordance with the Fermi distribution, and the values of electrochemical potentials

Summing up, it is stated that the reason of the current is the difference in the preparation of the equilibrium states of contacts, displayed by their respective Fermi function  $f_1(E)$  and  $f_2(E)$ . Qualitatively, this is true for any conductors – nanoscale and macrodimension ones. However, for nanoscale conductors the current is proportional to the difference  $I(E) \sim f_1(E) - f_2(E)$  of the Fermi distributions in both contacts at any value of the energy of the electronic states in a conductor. This difference vanishes if the energy  $E$  is greater  $\mu_1$  and  $\mu_2$ , as in this case; both the Fermi functions are zero. This difference also vanishes if the energy  $E$  is smaller  $\mu_1$  and  $\mu_2$ , as in this case, both the Fermi functions are equal to one. Current arises only in the window  $\mu_1 - \mu_2$ , if it contains at least one electronic state of the conductor.

## 5. LINEAR RESPONSE

The current-voltage characteristic is usually non-linear, but it could be single out plot of "linear response", which implies conductance  $dI/dV$  at  $V \rightarrow 0$ .

We construct the function of the difference of the two Fermi functions, normalized to the applied voltage

$$F(E) = \frac{f_1(E) - f_2(E)}{qV/kT}, \quad (12)$$

Where

$$\begin{aligned} \mu_1 &= \mu_0 + (qV/2) \\ \mu_2 &= \mu_0 - (qV/2) \end{aligned} \quad (13)$$

Function of the difference  $F(E)$  is narrowed as the voltage  $V$ , multiplied by the charge of the electron, becomes smaller than  $kT$  (Fig. 5). Note also that as  $kT$  begins to exceed the energy  $qV$ , function  $F(E)$  is getting closer to the function of the thermal broadening (5)  $F(E) \rightarrow F_T(E)$  at  $qV/kT \rightarrow 0$ , so that from equations (12) follows that

$$f_1(E) - f_2(E) = \frac{qV}{kT} F_T(E, \mu_0) = \left( -\frac{\partial f_0}{\partial E} \right) qV \quad (14)$$

if the applied voltage multiplied by the electron charge,  $\mu_1 - \mu_2 = qV$  becomes much smaller  $kT$ .

We also need the following expression

$$f(E) - f_0(E) = -\frac{\partial f_0}{\partial E} (\mu - \mu_0) \quad (15)$$

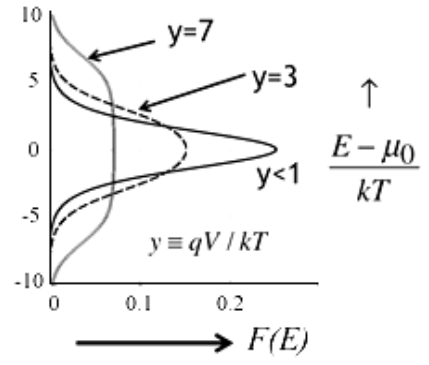

**Fig. 5** – The graph of the difference  $F(E)$  depending on the value  $(E - \mu_0)/kT$  for different  $qV/kT \equiv y$

which, like the equation (14), can be obtained as follows.

For the Fermi function

$$f(x) \equiv \frac{1}{e^x + 1}, \quad x \equiv \frac{E - \mu}{kT} \quad (16)$$

we have

$$\begin{aligned} \frac{\partial f}{\partial E} &= \frac{df}{dx} \frac{\partial x}{\partial E} = \frac{df}{dx} \frac{1}{kT} \\ \frac{\partial f}{\partial \mu} &= \frac{df}{dx} \frac{\partial x}{\partial \mu} = -\frac{df}{dx} \frac{1}{kT} \end{aligned} \quad (17)$$

$$\frac{\partial f}{\partial T} = \frac{df}{dx} \frac{\partial x}{\partial T} = -\frac{df}{dx} \frac{E - \mu}{kT^2}$$

where from

$$\begin{aligned} \frac{\partial f}{\partial \mu} &= -\frac{\partial f}{\partial E} \\ \frac{\partial f}{\partial T} &= -\frac{E - \mu}{T} \frac{\partial f}{\partial E} \end{aligned} \quad (18)$$

Equation (15) is obtained from the decomposition of the Fermi function in Taylor series near the point of equilibrium

$$f(E, \mu) \equiv f(E, \mu_0) + \left( \frac{\partial f}{\partial \mu} \right)_{\mu=\mu_0} (\mu - \mu_0). \quad (19)$$

From equation (18) it follows

$$\left( \frac{\partial f}{\partial \mu} \right)_{\mu=\mu_0} = \left( -\frac{\partial f}{\partial E} \right)_{\mu=\mu_0}. \quad (20)$$

Let  $f(E)$  corresponds to  $f(E, \mu)$ , and  $f_0(E)$  corresponds to  $f(E, \mu_0)$ , then

$$f(E) \approx f_0(E) + (\mu - \mu_0) \left( -\frac{\partial f}{\partial E} \right), \quad (21)$$

that after rearrangement gives the required equation (15), which is true for  $\mu - \mu_0 \ll kT$ .



*Preliminary results.* Conductivity of materials can vary by more than  $10^{20}$  times, going, for example, from silver to glass – the substances that very distant from each other in the scale of conductivity. The standard explanation for the difference in the conductivity is alleged that the density of "free electrons" in these materials is very different. This explanation immediately requires explanations which electrons are free, and which are not. This difference becomes more and more absurd as the transition to the nanoscale conductors.

The concept of "bottom-up" offers the following simple answer. Conductivity depends on the density of states in the window with width of a few  $kT$ , covering the equilibrium electrochemical potential  $\mu_0$ , defined by the function  $F_T$  (equation 5, Fig. 3), which is different from zero in a small gap with width a few  $kT$  around the equilibrium value of the electrochemical potential.

It's not in the total number of electrons, which is of the same order as in silver, and in the glass. The key point is the presence of the electronic states in the range of meaning of electrochemical potential  $\mu_0$  that basically distinguishes one substance from another.

The real answer is not new, and it is well known to experts in the field of nanoelectronics. However nowadays discussion usually starts with the Drude theory [13], which has played an important historical role in understanding the nature of the current. Unfortunately, the approach of the Drude spawned two misunderstandings that should be overcome, and especially in the teaching of physics, such as:

- (1) Current is generated by an electric field;
- (2) Current depends on the number of electrons.

Both misconceptions related to each other, as if the current would indeed be generated by an electric field, then all the electrons would be affected by the field.

Lessons learned from our experimental nanoelectronics, show that the current generated by the "preparation" of the two contacts  $f_1(E) - f_2(E)$ , and this difference is not zero only in the window around the equilibrium electrochemical potential  $\mu_0$ . Conductivity of the channel is high or low depends on the availability of the electronic states in the window. This conclusion usually come through the Boltzmann transport equation [14] or Kubo formalism [15], while we use the concept of "bottom-up" immediately gives a physically correct picture of the current.

## 6. MODEL OF ELASTIC RESISTANCE

Thus, the current generated by the "preparation" of the two contacts 1 and 2 with the Fermi functions  $f_1(E)$  and  $f_2(E)$ . The larger value of the electrochemical potential corresponds to negative terminal 1, and a lower value – to positive. Negative terminal is willing to transfer the electrons in the conduction channel, and positive contact seeks to extract electrons from the conduction channel. This is true for any conductors – either nanoscale, or macrodimension.

Model of elastic resistor serves as a useful idealization that provides physically correct explanation of functioning of nanoscale conductors and opens the possibility for a new interpretation of macrodimension devices. Rolf Landauer proposed the concept of «elastic resistor» in 1957 [9-11] long before its experimental

confirmation in nanotransistor. [1] The concept of "elastic resistor", strictly speaking, is an idealization, but it is reliably confirmed by numerous experimental data for ultra small nanotransistors. [3] Development of the concept of elastic resistor [6-8, 12] has led to the creation of a unified picture of transport phenomena in electronic devices of any dimension.

In the elastic resistor model electrons swaps the conduction channel from the source contact  $S$  to stock one  $D$  elastically, without loss or acquisition of energy (Fig. 6).

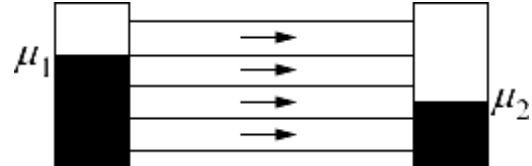

**Fig. 6** – In the elastic resistor electrons move ballistically through the channels with constant energy

Current in the range of energy from  $E$  to  $E + dE$  is separated from the channel in the elastic resistor with different values of energy that allows us to write for the current in the differential form

$$dI = dEG(E)(f_1(E) - f_2(E)), \quad (22)$$

and after integration to obtain an expression for the total current. Then, using the expression (14), we obtain the expression for the low voltage conductivity (linear response)

$$G \equiv \frac{I}{V} = \int_{-\infty}^{+\infty} dE \left( -\frac{\partial f_0}{\partial E} \right) G(E), \quad (23)$$

in which the negative derivative  $(-\partial f_0 / \partial E)$  can be thought as a rectangular impulse, whose area is equal to one and the width  $\sim \pm 2 kT$  (Fig. 3). According to (23), the conductivity function  $G(E)$  for the elastic resistor, being averaged over the range of  $\sim \pm 2 kT$ , which includes the value of the electrochemical potential  $\mu_0$ , gives the experimentally measured conductance  $G$ . At low temperatures, you can simply use the value of  $G(E)$  with  $E = \mu_0$ .

Such energetic approach to the conductivity in the elastic resistor model provides the significant simplification in understanding of the current causes, although it sounds paradoxical, because we traditionally associate the current  $I$  through the conductor with the resistance  $R$  and the Joule heat  $I^2R$ . How can we talk about resistance when electrons moving through a conductor do not lose energy?

The answer is that since the electrons do not lose energy when driving on elastic resistor, energy loss occurs at the conductor boundary with the source and stock contacts, where Joule heat is dissipated. In other words, the elastic resistance, characterized by the resistance  $R$  of the conductance channel, dissipates Joule heat  $I^2R$  outside of the conductance channel. This is indicated by the many different experimental measurements, direct and indirect, on the nanoscale conductors [3, 4], not to mention the fact that the dissipation of heat, whether a single molecule or nanoconductor,

would lead to their combustion, and the general opinion now is that the combustion does not occur in real experiments as overwhelming majority of the heat is generated at the contacts, which are quite massive and thus fairly easily dissipate heat.

The concept of elastic resistor does not include the obligatory follow of an electron along a straight path from the source to the drain and it is allowed the "diffusion" motion with the variable impulse vector, but no change in energy.

Model of elastic resistor is introduced not only as a useful concept for explaining the operation of nanoscale devices, but also because this model allows explaining the transport properties such as conductivity in macrodimension conductors. This model makes the concept of a "bottom-up" [8, 12] so effective in explaining the transport phenomena in general. We will return to this statement later, but now we will get the expression for the conductivity of the elastic resistor.

## 7. THE CONDUCTIVITY OF THE ELASTIC RESISTOR

In the spirit of the concept of "bottom - up", we will consider a simple elastic resistor with a single channel of energy  $\varepsilon$ , from which the electron jumps from the source to the drain (Fig. 7).

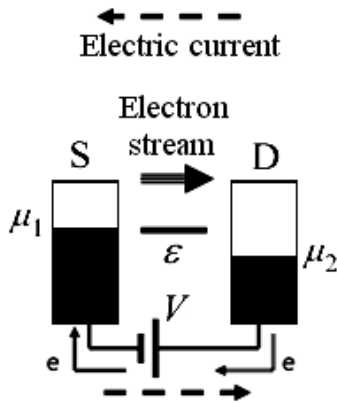

Fig. 7 – One-level model of elastic resistor with energy in the channel  $\varepsilon$

Recall that by assigning a negative charge to electron, which is not possible to change, the contact with more voltage  $D$  has a smaller electrochemical potential, and the motion of the electron through the channel comes from the larger value of the electrochemical potential to a smaller, so that the current direction is opposite to the actual movement of electrons from the source  $S$  to the drain  $D$ . In fact, we always have in mind that this is the real current of electrons, rather than the current in the usual sense.

The resulting single-channel current is

$$I = \frac{q}{t} (f_1(\varepsilon) - f_2(\varepsilon)) \quad (24)$$

where  $t$  is the time required for an electron leakage from the source  $S$  to the drain  $D$ . You can now generalize the expression (24) to arbitrary elastic resistor (Fig. 6) with the arbitrary density of states  $D(E)$ , bear-

ing in mind that all the energy channels in elastic resistor conduct independently and in parallel mode. First, we write down the expression for the current in the channel with the energy from  $E$  to  $E + dE$

$$dI = dE \frac{D(E)q}{2t} (f_1(E) - f_2(E)), \quad (25)$$

which takes into account that there are  $D(E)dE$  states in this channel and only half of them contribute to the current from the source  $S$  to the drain  $D$ . Integrating, we obtain an expression for the current through the elastic resistor

$$I = \frac{1}{q} \int_{-\infty}^{+\infty} dE G(E) (f_1(E) - f_2(E)), \quad (26)$$

where

$$G(E) = \frac{q^2 D(E)}{2t(E)}. \quad (27)$$

If the difference  $\mu_1 - \mu_2 = qV$  by voltages  $V$  on contacts is much smaller than  $kT$ , it is entitled to use equation (14) and write

$$I = V \int_{-\infty}^{+\infty} dE \left( -\frac{\partial f_0}{\partial E} \right) G(E), \quad (28)$$

which leads to the equation (23). In general case,

$$G = \frac{q^2 D}{2t}, \quad (29)$$

However, we must remember that the density of states  $D$  and the time of flight  $t$  in general case depend on the energy and should be averaged within  $\pm 2kT$ , including electrochemical potential  $\mu_0$ . This expression is submitted correct and intuitive. It argues that the conductivity is proportional to the product of two factors, namely, the presence of states ( $D$ ) and the ease with which the electron covers the distance from the source to the drain ( $1/t$ ). This is the key result for further discussion. Now we turn to the more detailed consideration of heat dissipation by the elastic resistor.

## 8. HEAT DISSIPATION BY ELASTIC RESISTOR

The resistance  $R$  of the elastic resistor is determined by the channel, and the corresponding heat  $P^R$  is released outside the conductance channel. Let us consider the situation on the example of a single-level model of the elastic resistor with energy in the channel  $\varepsilon$  (Fig. 7). Each time when an electron jumps ballistically the channel from the source, it is in the state of "hot

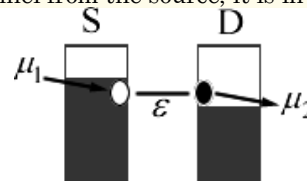
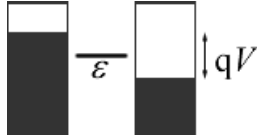

Fig. 8 – Instantaneous picture after breakthrough of electron from source to drain in the channel with energy  $\varepsilon$ , excess electrochemical potential of drain  $\mu_2$

electron" at the drain of energy  $\varepsilon$ , excess electrochemical potential of drain  $\mu_2$  (Fig. 8).

In the drain contact the dissipation processes quickly dissipate the excess energy  $\varepsilon - \mu_2$ . Similarly, on the source contact "hole" with energy  $\varepsilon$ , less than the electrochemical potential  $\mu_1$  of the source, filled with electrons, and the excess energy  $\mu_1 - \varepsilon$  dissipates on source (Fig. 9).



**Fig. 9** – After the ballistic flight of the electron from the source to the drain through the channel with energy  $\varepsilon$ , on source energy  $\mu_1 - \varepsilon$  is released, and on the drain the energy  $\varepsilon - \mu_2$  is released, and contacts are in balance again

The total energy dissipated on the contacts is  $\mu_1 - \mu_2 = qV$ . If  $N$  electrons skip from the source to the drain in the time  $t$ , then the power dissipated at the contacts

$$P = V \cdot I = qV \cdot N / t. \quad (30)$$

Thus, the heat generated by the passage of current in elastic resistor dissipates on the contacts, which already has experimental evidence for nano- and meso-dimensional conductors [16]. The attractiveness of the elastic resistor model is that the mechanical and thermodynamic processes are spatially separated.

### 9. MODEL OF ELASTIC RESISTOR AND MACROCONDUCTORS

It is natural to wonder about the validity and usefulness of the elastic resistor model to explain and understand the physics of the phenomenon of current flow in normal macroconductors, in which the electron motion is apparently inelastic. In macroconductors inelastic processes are combined with flexible and randomly distributed throughout the conductor (Fig. 10). We partition a macroconductor with randomly distributed the inelastic collisions on sequence of elastic resistors (Fig. 11) of length  $L$ , that much shorter than the real macroconductor, and with the voltage drop between the adjacent elastic resistors, which is the small fraction of the potential difference at the ends of the real conductor  $\mu_1 - \mu_2 = qV$ . In the partition the lengths  $L$  must be less than the length of  $L_{in}$ , which is the electron mean free path to the next inelastic collision. While partitioning except the condition  $L < L_{in}$  it should be comply the requirement that the voltage drop between the adjacent elastic resistors  $\Delta V < kT / q$ .

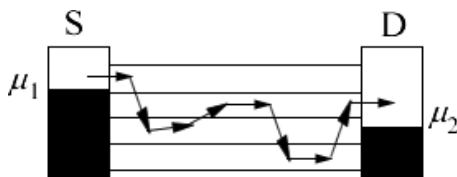

**Fig. 10** – In macroconductors the inelastic processes combined with elastic ones

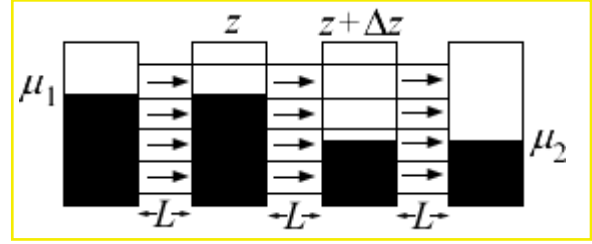

**Fig. 11** – Hypothetical partition of the real macroconductor on the series of the elastic resistors

Partitioning the large conductor to the elastic resistors requires some care. As will be shown below, the standard expression for Ohm's law should be changed to

$$R = \rho(L + \lambda) / A, \quad (31)$$

where  $A$  – the cross-sectional area of the conductor, in which the additional resistance  $\rho\lambda / A$  does not depend on the length of the conductor and can be interpreted as borderline resistance, which occurs at the boundary of the channel / contact. In the expression (31)  $\lambda$  is the length, which is close to the mean free path, so such modification of Ohm's law is significant only for ballistic conductors ( $L \sim \lambda$ ) and is not significant for large conductors ( $L \gg \lambda$ ). However, conceptually, this additional resistance will be extremely important if using the hypothetical structure in Fig. 11 to explain the real situation in Fig. 10. Structure in Fig. 11 has a lot of boundary interfaces that do not exist in the real situation (Fig. 10), so you should get rid of the virtual boundaries. For example, if a resistance (31) characterizes each section of length  $L$  in Fig. 11, the correct expression for the conductor in Fig. 10, for example, with the length  $3L$  will be

$$R = \rho(3L + \lambda) / A, \quad (32)$$

rather than

$$R = \rho(3L + 3\lambda) / A. \quad (33)$$

Thus, to obtain the correct expression for the conductivity of the long conductor in the frame of the elastic resistor model you should carefully separate the boundary resistance from the conductor resistance, depending on its length.

### 10. BALLISTIC AND DIFFUSIVE TRANSPORT

As we saw above, the conductivity of the elastic resistor is given by (29)  $G = q^2 D / 2t$ .

We will show that the transit time  $t$  through the resistor of length  $L$  in diffusion mode with the mean free path  $\lambda$  is related to the transit time in the ballistic regime  $t_B$  by ratio

$$t = t_B \left( 1 + \frac{L}{\lambda} \right). \quad (34)$$

Substituting (34) into (29) and taking into account that

$$G_B \equiv q^2 D / 2t_B \quad (35)$$

we will finally obtain for the conductivity in the diffusive mode

$$G = \frac{G_B \lambda}{L + \lambda}. \quad (36)$$

Inverting the conductivity (36), we will obtain for Ohm's law in a new formulation

$$R = \frac{\rho}{A} (L + \lambda), \quad (37)$$

where

$$\frac{\rho}{A} = \frac{1}{\sigma A} = \frac{1}{G_B \lambda}. \quad (38)$$

Until now, it was the three-dimensional resistor with a cross-section  $A$  (Fig. 12).

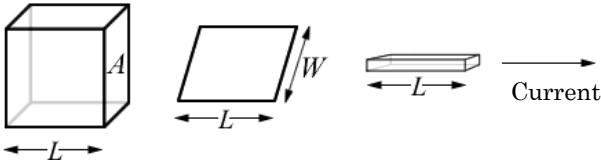

Fig. 12 – Conductors of dimension 3d, 2d and 1d

The various experiments are performed on two-dimensional conductors with a width  $W$  and single-dimensional cross-section. For such 2d-resistors the corresponding expressions for Ohm's law, obviously, have the form

$$R = \frac{\rho}{W} (L + \lambda) \quad (39)$$

where

$$\frac{\rho}{W} = \frac{1}{\sigma W} = \frac{1}{G_B \lambda}. \quad (40)$$

Finally, for one-dimensional conductors we have

$$R = \rho (L + \lambda), \quad (41)$$

where

$$\rho = \frac{1}{\sigma} = \frac{1}{G_B \lambda}. \quad (42)$$

We will write Ohm's law compactly for conductors of all three dimensions

$$R = \rho (L + \lambda) \left\{ 1, \frac{1}{W}, \frac{1}{A} \right\}, \quad (43)$$

where

$$\frac{1}{\rho} = \sigma = G_B \lambda \left\{ 1, \frac{1}{W}, \frac{1}{A} \right\}. \quad (44)$$

The expression in the curly brackets corresponds 1d-, 2d- and 3d-conductors. Note that the resistivity

and conductivity have different dimensions, depending on the dimensions of the conductor, and the conductivity and the length is still measured in meters and siemens.

Standard Ohm's law says that the resistance tends to zero with decreasing length of the conductor to zero. Nobody expects that the resistance becomes zero, but common consensus is that the resistance tends to the certain boundary resistance, which can be made arbitrarily small with the improvement of measurement technology. The experimentally established fact is that under the most carefully prepared contact the observed minimal resistance is associated with the channel conductance and is independent of the contact [2]. Modified Ohm's law reflects this fact: even at approaching the length conductor to zero the residual resistance associated with the effective length of  $\lambda$  is remained. It is appropriate, however, to ask yourself what sense is to talk about a non-zero length  $\lambda$  at zero length of the conductor. The answer is the fact that for nanoscale conductors neither resistivity  $\rho$ , nor the length  $\lambda$  has sense separately, and only their product is essential.

## 11. BALLISTIC AND DIFFUSIVE TRANSPORT

Consider how the density of states  $D$  and the time of flight  $t$  in the expression for the conductivity (29) correlate with the size of the channel in large conductors. As for the density of states, it is an additive property. At two times large channel has twice the electron states, so that the density of states for large conductors should be proportional to the volume of the conductor  $A \cdot L$ .

As for the time of flight  $t$ , it is usually considered two transport modes:

ballistic one with  $t \sim L$  and diffusion one with  $t \sim L^2$ . Ballistic conductance is proportional to the cross sectional area of the conductor and, according to (29) does not depend on the length of the conductor. Such "non-ohmic" behavior is actually observed in nanoscale conductors [17]. As for conductors with diffusive transport mode, they show normal "ohmic" behavior of the conductivity  $G \sim A / L$ .

The difference of the two transport modes can be explained as follows. In the ballistic regime the time of flight from the source to the drain

$$t_B = \frac{L}{\bar{u}}, \quad (45)$$

where

$$\bar{u} = \langle |v_z| \rangle \quad (46)$$

is the average velocity of the electrons along the axis  $z$  of the motion direction of electrons from source to drain.

In the case of the diffusion mode time  $t$  quadratically depends on the length of the conductor

$$t = \frac{L}{\bar{u}} + \frac{L^2}{2\bar{D}}, \quad (47)$$

where the value  $\bar{D}$  is the diffusion coefficient in the frame of theory of random walks [18]



$$\bar{D} = \langle v_z^2 \tau \rangle \quad (48)$$

where  $\tau$  is the mean free time.

Using (45), we rewrite the (47) in the form

$$t = t_B \left( 1 + \frac{L\bar{u}}{2\bar{D}} \right), \quad (49)$$

which together with the equation (34) for the length of  $\lambda$  yields

$$\lambda = \frac{2\bar{D}}{\bar{u}}. \quad (50)$$

To calculate the constants  $\bar{u}$  according to the equation (46) and  $\bar{D}$  according to the equation (48) it is required to the average electrons velocity in the direction of their movement (axis  $z$ ) for all angular variables, depending on the dimension of the conductor  $d = \{1, 2, 3\}$ . Simple calculations yield for

$$\text{1d-conductor} \quad \langle |v_z| \rangle = v \quad \text{and} \quad \langle |v_z^2| \rangle = v^2, \quad (51)$$

$$\text{2d-conductor} \quad \langle |v_z| \rangle = 2v/\pi \quad \text{and} \quad \langle |v_z^2| \rangle = v^2/2, \quad (52)$$

$$\text{3d-conductor} \quad \langle |v_z| \rangle = v/2 \quad \text{and} \quad \langle |v_z^2| \rangle = v^2/3, \quad (53)$$

with the result that

$$\bar{u} = \langle |v_z| \rangle = v(E) \left\{ 1, \frac{2}{\pi}, \frac{1}{2} \right\}, \quad (54)$$

$$\bar{D} = \langle v_z^2 \tau \rangle = v^2 \tau(E) \left\{ 1, \frac{1}{2}, \frac{1}{3} \right\}, \quad (55)$$

or finally for the mean free path  $\lambda$  we have

$$\lambda = \frac{2\bar{D}}{\bar{u}} = v\tau \left\{ 2, \frac{\pi}{2}, \frac{4}{3} \right\}. \quad (56)$$

We emphasize that the length  $\lambda$  includes a numerical factor depending on the dimensions of the conductor, as compared to its standard value of  $\lambda = v \times \tau$ . Can we use this standard value of  $\lambda$ ? Yes, we can, but then in the new formulation of Ohm's law (43)  $L$  should not only be replaced by  $L + \lambda$ , but add  $\lambda$  to  $L$ , multiplied by the numerical factor that depends on the dimension of the conductor, or use the definition of the length of  $\lambda$  in (56). It's curious that this factor even for one-dimensional conductor is not equal to one, and is two. The value of  $\tau$  is the mean free time of the flight to the next encounter. Since the scattering is assumed to be isotropic, only half of the acts collision leads the electron from the source to the drain. With regard for the inverse scattering the length value for  $\lambda$  for 1d-conductor is equal  $2v\tau$ .

Now we will obtain the equation for the ballistic conductance. From equations (35) and (45) we have

$$G_B \equiv q^2 D \bar{u} / 2L, \quad (57)$$

and substituting equations (54), we obtain

$$G_B \equiv \frac{q^2 D v}{2L} \left\{ 1, \frac{2}{\pi}, \frac{1}{2} \right\}. \quad (58)$$

Finally, substituting (56) and (58) into (44) and taking (55) we will obtain for the conductivity

$$\sigma = q^2 \bar{D} \frac{D}{L} \left\{ 1, \frac{1}{W}, \frac{1}{A} \right\}. \quad (59)$$

So, the expressions for the conductivity in the ballistic mode (59) and diffusion mode (36) are obtained based on the general expression for the conductivity (29) and transit times (45) and (47).

## 12. CONDUCTIVITY MODES

From equation (58) it is shown that the ballistic conductance is proportional to the density of states per unit length of the conductor  $D/L$ . Since the density of states is proportional to the volume, it can be expected that the ballistic conductance is proportional to the cross sectional area  $A$  of the 3d-conductor or width  $W$  of the 2d-conductor.

Numerous experiments have shown [17] that for nanoscale conductors the ballistic conductivity does not vary linearly with their cross-sectional area, and multiple of the quantum of conductance

$$G_B \equiv \frac{q^2}{h} M. \quad (60)$$

In other words, the real conductor can be considered as  $M$  independent modes of conduction, giving a total ballistic conduction. Taking into account (58), we obtain for the number of conduction modes

$$M \equiv \frac{h D v}{2L} \left\{ 1, \frac{2}{\pi}, \frac{1}{2} \right\}, \quad (61)$$

and from equations (44) and (60) the conductivity is expressed through the number of conduction modes  $M$  and the mean free path  $\lambda$

$$\sigma = \frac{q^2}{h} M \lambda \left\{ 1, \frac{1}{W}, \frac{1}{A} \right\}. \quad (62)$$

We will explain in complete detail the concept of conduction modes hereafter.

## 13. FUNDAMENTAL RELATIONSHIP

Standard expression for the conductivity is given by the Drude formula [13] relating the conductivity  $\sigma$  with the electron density  $n$ , the effective mass  $m$  and the mean free time  $\tau$

$$\sigma \equiv \frac{1}{\rho} = \frac{q^2 n \tau}{m}, \quad (63)$$

or using the concept of mobility

$$\bar{\mu} = \frac{q\tau}{m}, \quad (64)$$

we have

$$\sigma = qn\bar{\mu}. \tag{65}$$

On the other hand, it results in two equivalent expressions for the conductivity in the concept of a "bottom-up", one of which expresses the conductivity through the product of the density of states and the diffusion coefficient  $D$  (59), and the other – through the product of the number of modes  $M$  in the channel of conductance and the average mean free path  $\lambda$  (62).

As the conductance

$$G \equiv \frac{I}{V} = \int_{-\infty}^{+\infty} dE \left( -\frac{\partial f_0}{\partial E} \right) G(E),$$

conductivity of the equations (59) and (62) must be average over the energy of a few  $kT$ , including  $E = \mu_0$  using the function of the thermal broadening

$$\sigma = \int_{-\infty}^{+\infty} dE \left( -\frac{\partial f_0}{\partial E} \right) \sigma(E). \tag{66}$$

Equation (59) is well known, it is deduced in the standard textbooks on solid state physics [13], which is not an equivalent equation (62), the deduce of which usually requires the use of statistical thermodynamics of irreversible processes such as the Kubo formalism [14, 15].

As for the Drude model we would like to emphasize the following. The applicability of the Drude model is very limited, while the equation for the conductivity (59) and (62) have the most general meaning. For example, these equations are applicable to graphene [19, 20] with nonparabolic behavior of zones and "massless" electrons – with properties that can't be described in the Drude model. One of the lessons learned by nanoelectronics is broad applicability of the equations for the conductivity (59) and (62).

The fundamental difference between (59) and (62) and the Drude theory is that the averaging (66) makes the conductivity as property of the Fermi surface: the conductivity is determined by the energy levels close to  $E = \mu_0$ . And according to the equations (63)-(65) of the Drude theory conductivity depends on the total electron density, summed over the entire spectrum of energy, which leads to the limited applicability of the Drude model. Conductivity of materials varies widely in spite of the fact that the number of electrons approximately equal. Low glass conductivity not because there are few of so-called "free" electrons in it; glass is characterized

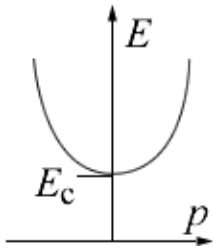

**Fig. 14** – The parabolic dispersion

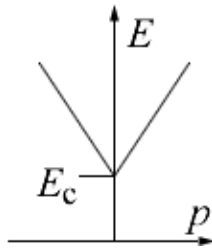

**Fig. 15** – The linear dispersion

by a very low density of states and the number of modes near  $E = \mu_0$ . The concept of a "free" electron belongs to intuitive concept.

For any conductor, either with the crystal or amorphous structure, and for molecular conductors, following [12], we show that, regardless of the functional dependence of  $E(p)$ , the density of states  $D(E)$ , velocity  $v(E)$  and impulse  $p(E)$  are related to the number of electron states  $N(E)$  with energy less than the values of  $E$ , by the ratio of

$$D(E)v(E)p(E) = N(E) \cdot d, \tag{67}$$

where  $d$  – the dimension of the conductor. Using (67) to calculate the conductivity (59) with the diffusion coefficient (55)

$$\bar{D} = \langle v_z^2 \tau \rangle.$$

we obtain for 3d-conductor

$$\sigma(E) = q^2 \frac{N(E) \tau(E)}{A \cdot L m(E)}. \tag{68}$$

where the mass is defined as

$$m(E) = \frac{p(E)}{v(E)}. \tag{69}$$

It is easy to see that the fundamental relation (67) is valid for the parabolic dependence of  $E(p)$  and linear as in graphene [20]. For the parabolic dependence the mass of the carrier does not depend on the energy, which is not so in general case.

Equation (68) looks like the expression (63) of the Drude theory, if to assume  $N / A \cdot L$  as the electron density  $n$ . At low temperatures, it is true, as the average (66) at  $E = \mu_0$  gives

$$\sigma = \left( q^2 \frac{N}{A \cdot L m} \tau \right)_{E=\mu_0} = q^2 n \tau / m, \tag{70}$$

as  $N(E)$  with  $E = \mu_0$  is the total number of electrons (Fig. 13). At nonzero temperature the situation is all the more sobdifficult if the density states is nonparabolic. Note that the key factor in the reduction of the general expression for the conductivity (59) to (68), similar to the Drude formula (63), there is the fundamental expression (67) connecting the density of states  $D(E)$ , velocity  $v(E)$  and impulse  $p(E)$  for the given value of the energy with the total number of states  $N(E)$ , obtained by integrating the density

How the total number of states  $N(E)$  in (71) can be unambiguously associated with the density of states  $D(E)$ , velocity  $v(E)$  and impulse  $p(E)$  for the specific value of energy? The answer is in the fact that (67) is satisfied only when the energy levels are calculated explicitly from the expression for  $E(p)$ . It may not be in the energy region of the overlapping bands or, for example, for amorphous, when the function  $E(p)$  is not known. In these cases, the equations (59) and (62) are not equivalent to (68) and you can use only the first one.

$$N(E) = \int_{-\infty}^E dE D(E). \quad (71)$$

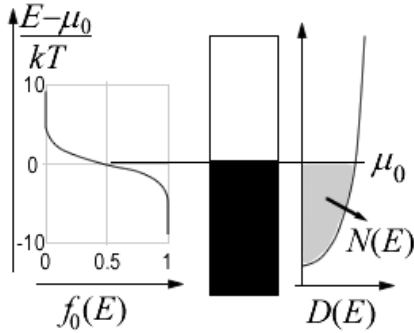

**Fig. 13** –The equilibrium Fermi function  $f_0(E)$ . The density of states  $D(E)$  and the total number of electrons  $N(E)$

Let's see how single zones described by the different ratios of  $E(p)$  leads to the fundamental equation (67), and thus opens the possibility to establish the relationship between the expressions for the conductivity (59) and (62) and Drude formulas (63-65). It will also lead to a new interpretation of modes  $M(E)$ , introduced above, and to explanation of their integrality.

#### 14. DISPERSION $E(p)$ FOR CRYSTALLINE SOLIDS

Let the standard relation between energy and impulse is parabolic (Fig. 14)

$$E(p) = E_c + \frac{p^2}{2m}, \quad (72)$$

where  $m$  is the effective mass. We will use the relation  $E(p)$  instead of  $E(k)$ , although you can always go to the wave vector  $k = p / \hbar$ . Dispersion (72) is widely used for various substances – for metals and semiconductors. But this is not the only possibility. For graphene [19, 20], which use in nanoelectronics is expected to lead to the next step in miniaturization, it takes place linear dependence from impulse (Fig. 15)

$$E = E_c + v_0 p, \quad (73)$$

where  $v_0$  – the constant equal to about 1/300 of the speed of light. Here and formerly it is used absolute value of impulse  $p$ . In other words, it is implied that the dependence of  $E(p)$  is isotropic.

For isotropic  $E(p)$  the velocity is parallel to the impulse, and its value is equal to

$$v \equiv \frac{dE}{dp}. \quad (74)$$

#### 15. TO COUNTING THE NUMBER OF STATES

The length  $L$  resistor must fit an integer de Broglie waves with length  $\lambda = h / p$

$$\frac{L}{h/p} = \text{integer or } p = \text{integer} \cdot (h/L).$$

This means that the allowed states are uniformly

distributed for given value of  $p$  and each of the states occupies the interval

$$\Delta p = \frac{h}{L}. \quad (75)$$

We define  $N(p)$  as the total number of states with the values of the impulse less than the specified value of  $p$ . For one-dimensional conductors  $1d$  (Fig. 16) this function is the ratio of available length  $2p$  (from  $-p$  to  $+p$ ) to the interval  $\Delta p$

$$N(p) = \frac{2p}{h/L} = 2L \left( \frac{p}{h} \right). \quad (76)$$

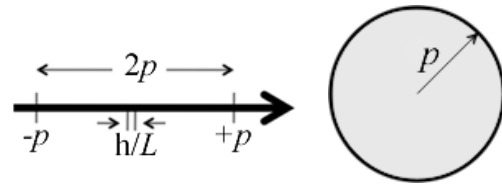

**Fig. 16** – To counting the number of states for the  $1d$ -conductor

**Fig. 17** – To counting the number of states for  $2d$ -conductor

For  $2d$ -conductors (Fig. 17) it must be divided the cross sectional area  $\pi r^2$  on intervals with the length of  $h / L$  and cross-sectional area  $h / W$ , so that finally

$$N(p) = \frac{\pi p^2}{(h/L)(h/W)} = \pi W \cdot L \left( \frac{p}{h} \right)^2. \quad (77)$$

For  $3d$ -conductors the volume of sphere of radius  $r$  is divided on the product of the intervals  $(h / L) \times (h / W_1) \times (h / W_2)$ , where the cross-sectional area  $A = W_1 \times W_2$ , so that finally

$$N(p) = \frac{(4\pi/3)p^3}{(h/L)(h^2/A)} = \frac{4\pi}{3} A \cdot L \left( \frac{p}{h} \right)^3, \quad (78)$$

or gathering together for  $d = \{1, 2, 3\}$  we have

$$N(p) = \left\{ 2 \frac{L}{h/p}, \pi \frac{L \cdot W}{(h/p)^2}, \frac{4\pi}{3} \frac{L \cdot A}{(h/p)^3} \right\}. \quad (79)$$

Specifying the dispersion law  $E(p)$ , we can now calculate the dependence of the number of states  $N(E)$  energy less than the given value of  $E$ .

#### 16. THE DENSITY OF STATES $D(E)$

Resulting the function of the number of states  $N(E)$  must be equal to the density of states  $D(E)$ , integrated over up to the state energy  $E$

$$N(E) = \int_{-\infty}^E dE D(E),$$

so that the density of states

$$D(E) = \frac{dN}{dE} \quad (80)$$

and using equations (79)

$$D(E) = \frac{dN}{dp} \frac{dp}{dE} = \frac{dp}{dE} \frac{p^{d-1} d}{h^d} \left\{ 2L, \pi LW, \frac{4}{3} \pi LA \right\}. \quad (81)$$

Using (74) and (79) we finally obtain the required fundamental equation (67), independent of the dispersion law.

## 17. DRUDE FORMULA

As it has been shown, using (67) to calculate the conductivity (59) for the 3d-conductor we obtain the expression (68), in which mass depending on the energy is determined by equation (69). It was also shown that equation (68) reduces to the Drude formula (63) at temperatures close to zero. Now consider the conductor of  $n$ -type and  $p$ -type separately at temperatures different from zero.

### 17.1 $n$ -type conductors

Using equation (68), and assuming its independence of the mass  $m$  and the time  $\tau$  from the energy, we obtain

$$\sigma = \frac{q^2 \tau}{m} \frac{1}{A \cdot L} \int_{-\infty}^{+\infty} dE \left( -\frac{\partial f_0}{\partial E} \right) N(E). \quad (82)$$

Integrating by parts, we have

$$\begin{aligned} \int_{-\infty}^{+\infty} dE \left( -\frac{\partial f_0}{\partial E} \right) N(E) &= [-N(E) f_0(E)]_{-\infty}^{+\infty} + \int_{-\infty}^{+\infty} dE \frac{dN}{dE} f_0(E) \\ &= [0 - 0] + \int_{-\infty}^{+\infty} dE D(E) f_0(E) = \text{the total number of electrons,} \end{aligned} \quad (83)$$

since the product  $dE \times D(E) \times f_0(E)$  is the number of electrons in the energy range from  $E$  to  $E + dE$ . Thus, equation (82) reduces to the Drude

$$\sigma = \frac{q^2 \tau}{m} \frac{N}{A \cdot L}, \quad (84)$$

keeping in mind that  $N/A \times L = n$ .

### 17.2 $p$ -type conductor

An interesting situation occurs for the  $p$ -conductors with the downward dispersion, for example,

$$E(p) = E_c - \frac{p^2}{2m}. \quad (85)$$

Instead of the number of states in (71) we now have (Fig. 18)

$$N(E) = \int_E^{+\infty} dE D(E) \quad (86)$$

which gives

$$D(E) = -\frac{dN}{dE}. \quad (87)$$

Since the function  $N(E)$  is determined by the function  $N(p)$ , which gives the total number of states with impulse less than a given value of  $p$ , which corresponds

to the energy larger than the given value of  $E$  according to the dispersion relation (85).

If, as before, we integrate by parts

$$\begin{aligned} \int_{-\infty}^{+\infty} dE \left( -\frac{\partial f_0}{\partial E} \right) N(E) &= [-N(E) f_0(E)]_{-\infty}^{+\infty} + \\ &+ \int_{-\infty}^{+\infty} dE \frac{dN}{dE} f_0(E) \end{aligned}, \quad (88)$$

now the first summand does not vanish, since  $N(E)$  and  $f_0(E)$  in the lower limit is not zero.

This situation can be bypassed in the following way: to take the derivative of  $(1 - f_0)$  instead of taking the derivative of  $f_0$

$$\begin{aligned} \int_{-\infty}^{+\infty} dE \left( -\frac{\partial(1-f_0)}{\partial E} \right) N(E) &= \\ &= [-N(E)(1-f_0(E))]_{-\infty}^{+\infty} + \int_{-\infty}^{+\infty} dE \frac{dN}{dE} (1-f_0(E)) \end{aligned} \quad (89)$$

$$= [0 - 0] + \int_{-\infty}^{+\infty} dE D(E) (1-f_0(E)) =$$

the total number of "holes".

In other words, for the  $p$ -type conductors you can use the Drude formula

$$\sigma = q^2 n \tau / m, \quad (90)$$

if the value of  $n$  means the number of "holes": smaller number of electrons corresponds to larger value of  $n$ .

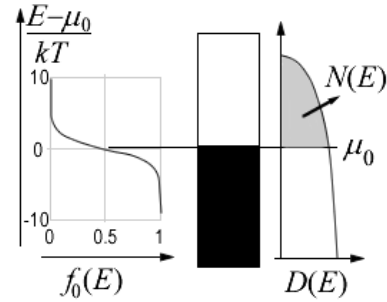

Fig. 18 – The equilibrium Fermi function  $f_0(E)$ , the density of states  $D(E)$  and the number of states  $N(E)$  for the  $p$ -conductor with the dispersion (85)

### 17.3 Graphene

How to calculate the value of  $n$  when zones spread in both directions as in graphene with dispersion  $E = \pm v_0 p$  [19, 20] (Fig. 7, left). It is impossible not to recognize the ingenious to split zone in graphene on the  $n$ -type zone and  $p$ -type zone (Fig. 19, right), so that

$$D(E) = D_n(E) + D_p(E) \quad (91)$$

and then use the formulas of Drude.

It has to be emphasized that there is no need for such ingenuity, because (59) and (62) are applied in all cases and correctly reflect the physics of conduction.

## 18. IS THE CONDUCTIVITY PROPORTIONAL TO THE ELECTRON DENSITY?



Experimental measurements of the conductivity are often performed depending on the electron density, which, according to the Drude theory, related linearly, so that the deviation from linearity is interpreted as a manifestation of the dependence of the mean free path of energy. They do not take into account that, for non-parabolic dispersion the mass of the current carrier defined as  $p/v$  may depend on the energy and thus lead to nonlinearity of conduction from the electron density.

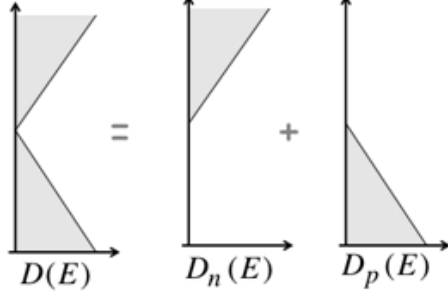

**Fig. 19** – Artificial splitting of the band structure of graphene on the zone of  $n$ - and  $p$ -type

First, we will define the electron density from the equation (79)

$$n(p) = \left\{ 2\frac{p}{h}, \pi\frac{p^2}{h^2}, \frac{4\pi}{3}\frac{p^3}{h^3} \right\}, \quad (92)$$

where  $n$  is the density of  $N/L$ ,  $N/W \times L$  and  $N/A \times L$  for  $d = 1, 2$ , and  $3$ . Rewrite (92) as

$$n(p) = K p^d, \quad (93)$$

where the proportionality factor  $K = \{2/h, \pi/h^2, 4\pi/3h^3\}$ . Now for the conductivity (70) with (69) we have

$$\sigma = q^2 \frac{n(p)\tau(p)}{m(p)} = q^2 K p^{d-1} v(p)\tau(p). \quad (94)$$

If it is known or chosen the dependence of velocity and time of the mean free path on the energy, and therefore also on the impulse, in the equations (93) and (94) we can get rid of dependence on the impulse and thus establish the link between the conductivity  $\sigma$  and the electron density  $n$ .

For example, in the case of graphene,  $E = \pm v_0 p$ , the rate  $dE/dp$  is constant and equal to  $v_0$ , and is independent of the impulse. Assuming the free path time independent of energy, the dependence of the conductivity on the electron density from the equations (93) and (94) and considering equation (56) for the mean free path

$$\lambda = \frac{2\bar{D}}{\bar{u}} = v\tau \left\{ 2, \frac{\pi}{2}, \frac{4}{3} \right\}$$

we obtain the following

$$\sigma = \frac{q^2}{h} \lambda \sqrt{\frac{4n}{\pi}} \quad (95)$$

or with the  $g$ -factor (for graphene  $g = 4$ )

$$\sigma = \frac{q^2}{h} \lambda \sqrt{\frac{4gn}{\pi}}. \quad (96)$$

Thus, the conductivity in graphene is obtained proportional  $\sim \sqrt{n}$ , but not as it is usually assumed  $\sim n$ , and with the mean free time, independent of energy. Calculation with (96) with  $\lambda = 2 \mu\text{m}$  and  $\lambda = 300 \text{ nm}$  (Fig. 20) are in agreement with experimental data [21].

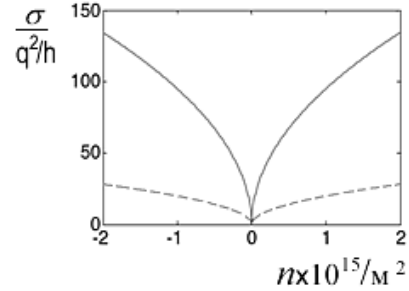

**Fig. 20** – The conductivity of graphene according to (96) as the function of the electron density for the values of  $\lambda = 2 \mu\text{m}$  (solid) and  $\lambda = 300 \text{ nm}$  (dotted line) is consistent with the experimental data (Fig. 1 in [21])

## 19. QUANTIZATION OF CONDUCTANCE AND CONDUCTIVITY MODES

Ballistic conductance is quantized

$$G_B \equiv \frac{q^2}{h} M.$$

where for low-dimensional conductors at low temperatures the number of  $M$  is integer. Above an expression for the number of modes

$$M \equiv \frac{\hbar D v}{2L} \left\{ 1, \frac{2}{\pi}, \frac{1}{2} \right\} \quad (97)$$

through the product of the density of states  $D$  and the electron velocity  $v$ , and quite non obvious the integer of expression (97). Using the expression for the dispersion of  $E(p)$ , it is possible to give another interpretation of  $M(p)$  indicating the integer nature of  $M$

Using (67), we rewrite (97) as

$$M = \frac{\hbar N}{2L p} \left\{ 1, \frac{4}{\pi}, \frac{3}{2} \right\}, \quad (98)$$

where  $N(p)$  is the total number of states with impulse less than the given value of  $p$ . Using (79) we transform (98) to

$$M(p) = \left\{ 1, 2\frac{W}{h/p}, \pi\frac{A}{(h/p)^2} \right\}. \quad (99)$$

As well as the number of states  $N(p)$  gives us the number of de Broglie wavelengths that stacked in the conductor, and  $M(p)$  gives the number of modes that stacked in the cross section of the conductor, and this number is independent of the dispersion law, since for the derivation of (99) any specific dispersion law was not used.

In practice while assessing the number  $N(p)$  and  $M(p)$  in the specific task it is obtained, of course, the fractional numbers. However, these numbers must be integer by the physical meaning. In large conductors at high temperatures the quantization of  $M(p)$  is smeared, however, in the meso- and nanoscale conductors the integer nature of the number of modes  $M(p)$  and the quantization of conductance are observed. Therefore, it is more correct to rewrite equation (99) as

$$M(p) = \text{Int} \left\{ 1, 2 \frac{W}{h/p}, \pi \frac{A}{(h/p)^2} \right\}, \quad (100)$$

where  $\text{Int} \{x\}$  means the greatest integer number less than value of  $x$ .

In one-dimensional conductors the number of modes coincides with the  $g$ -factor equaled to the number of valleys, multiplied by the spin degeneracy of 2. Resistance of the ballistic conductors  $\sim M \times h/q^2$ , so that the resistance of the ballistic 1d-conductor is approximately equal to  $25 \text{ K}\Omega$ , divided by  $g$ , that is observed experimentally [1]: most metals and semiconductors such as *GaAs* have  $g=2$  and the ballistic 1d-sample resistance of order of  $12.5 \text{ K}\Omega$ , and carbon nanotubes are two-valley with  $g=4$  and their ballistic resistance of order of  $6.25 \text{ K}\Omega$ .

This work is the result of prof. Yu.A. Kruglyak visit to the «Fundamentals of Nanoelectronics, Part I: Basic Concepts» and «Fundamentals of Nanoelectronics, Part II: Quantum Models» course lectures, given on-line in January – April, 2012 by prof. Supriyo Datta in the framework of the Purdue University initiative / nanoHUB-U [www.nanohub.org/u].

### Наноэлектроника: возникновение тока, новая формулировка закона Ома и моды проводимости в концепции «снизу–вверх»

Ю.А. Кругляк<sup>1</sup>, П.А. Кондратенко<sup>2</sup>, Ю.М. Лопаткин<sup>3</sup>

<sup>1</sup> Одесский государственный экологический университет, ул. Львовская, 15, 65016 Одесса, Украина

<sup>2</sup> Национальный авиационный университет, пр. Космонавта Комарова, 1, 03058 Киев, Украина

<sup>3</sup> Сумский государственный университет, ул. Римского-Корсакова, 2, 40007 Сумы, Украина

В рамках концепции «снизу – вверх» теоретической и прикладной наноэлектроники рассматриваются общие вопросы электронной проводимости, причины возникновения тока и роль электрохимических потенциалов и фермиевских функций в этом процессе, модель упругого резистора, баллистический и диффузионный транспорт, моды проводимости, проводники  $n$ - и  $p$ -типа и графен и дается новая формулировка закона Ома.

**Ключевые слова:** Наноэлектроника, Молеетроника, Снизу-Вверх, Закон Ома.

### Наноелектроніка: виникнення струму, нове формулювання закону Ома і моди провідності в концепції «знизу–вгору»

Ю.О. Кругляк<sup>1</sup>, П.О. Кондратенко<sup>2</sup>, Ю.М. Лопаткін<sup>3</sup>

<sup>1</sup> Одеський державний екологічний університет, вул. Львівська, 15, 65016 Одеса, Україна

<sup>2</sup> Національний авіаційний університет, пр. Космонавта Комарова, 1, 03058 Київ, Україна

<sup>3</sup> Сумський державний університет, вул. Римського-Корсакова, 2, 40007 Суми, Україна

В рамках концепції «знизу – вгору» теоретичної і прикладної наноелектроніки розглядаються загальні питання електронної провідності, причини виникнення струму та роль електрохімічних потенціалів і фермиевських функцій в цьому процесі, модель пружного резистора, балістичний і дифузійний транспорт, моди провідності, провідники  $n$ - і  $p$ -типу та графен, дається нове формулювання закону Ома.

**Ключові слова:** Наноелектроніка, Молеетроніка, Знизу-Вгору, Закон Ома.

### REFERENCES

1. V.V. Mitin, V.A. Kochelap, M.A. Strosio, *Introduction to Nanoelectronics: Science, Nanotechnology, Engineering, and Applications* (Cambridge: Cambridge University Press: 2012).
2. Hoefflinger Bernd (Editor), *Chips 2020: A Guide to the Future of Nanoelectronics (Frontiers Collection)*, (Berlin: Springer-Verlag: 2012).
3. J.M. Martínez-Duart, R.J. Martín-Palma, F. Agulló-Rueda, *Nanotechnology for Microelectronics and Optoelectronics* (London: Elsevier: 2005).
4. V.P. Dragunov, I.G. Neizvestnyi, V.A. Gridchin, *Basics of Nanoelectronics* (Moscow: Logos: 2006).
5. R.H.M. Smit, Y. Noat, C. Untiedt, N.D. Lang, M.C. van Hemert, J.M. van Ruitenbeek, *Nature* **419**, N 3, 906 (2002).
6. Datta Supriyo, *Electronic Transport in Mesoscopic Systems* (Cambridge: Cambridge University Press: 2001).

7. Datta Supriyo, *Quantum Transport: Atom to Transistor* (Cambridge: Cambridge University Press: 2005).
8. *Electronics from the Bottom Up: A New Approach to Nanoelectronic Devices and Materials* [Electronic resource] // [www.nanohub.org/topics/ElectronicsFromTheBottomUp](http://www.nanohub.org/topics/ElectronicsFromTheBottomUp)
9. Rolf Landauer, *IBM J. Res. Dev.* **1**, N 3, 223 (1957).
10. Rolf Landauer, *Philos. Mag.* **21**, 863 (1970).
11. Rolf Landauer, *J. Math. Phys.* **37**, N 10, 5259 (1996).
12. Datta Supriyo, *Lessons from Nanoelectronics: A New Perspective on Transport* (Hackensack, New Jersey: World Scientific Publishing Company: 2012).
13. N.W. Ashcroft, N.D. Mermin. *Solid State Physics* (New York: Holt, Rinehart and Winston: 1976).
14. F.W. Sears, G.L. Salinger, *Thermodynamics, Kinetic Theory, and Statistical Thermodynamics* (Boston: Addison-Wesley: 1975).
15. R. Kubo, *J. Phys. Soc. Japan* **12**, 570 (1957).
16. M. Lundstrom, Guo Jing, *Nanoscale Transistors: Physics, Modeling and Simulation* (Berlin: Springer: 2006).
17. Yu.V. Nazarov, Ya.M. Blanter, *Quantum Transport. Introduction to nanoscience* (Cambridge: Cambridge University Press: 2009).
18. Berg Howard C., *Random walks in biology* (Princeton: Princeton University Press: 1993).
19. M.V. Strikha, *Sensor Electronics Microsyst. Tech.* **1(7)**, N 3, 5 (2010).
20. Yu.A. Kruglyak, N.E. Kruglyak, *Visnyk Odessa State Environmental Univ.* N 13, 207 (2012).
21. K.I. Bolotin, K.J. Sikes, J. Hone, P. Kim, H.L., *Phys. Rev. Lett.* **101**, 096802/1-4 (2008).